



TOP-OF-POLE MOUNTING (TPM) : 6X-TPM-ADJ-series

Ameresco Solar manufactures and distributes a complete line of mounting kits to accommodate a wide range of off-grid applications. From single module top-of-pole mounts to complex multi-panel arrays, our mounting line has the flexibility to meet your needs.

Our Top-of-Pole Mounts Feature :

Rugged Materials and Construction, Precision Engineering and Expert Support

Table1:

Top-of-Pole : Guidelines For Pole Selection

Module Area	Pole Size	Depth In Ground	Height Above Ground	Hole Diameter
15 SQ. FT.	2" SCH40 (2-3/8" OD)	30"-36"	48"-72"	8"-12"
20 SQ. FT.	2.5" SCH40 (2-7/8" OD)	34"-40"	48"-72"	10"-14"
28 SQ. FT.	3" SCH40 (3-1/2" OD)	36"-42"	48"-72"	12"-16"
35 SQ. FT.	3" SCH40 (3-1/2" OD)	38"-44"	60"-72"	12"-16"
60 SQ. FT.	4" SCH40 (4-1/2" OD)	42"-48"	60"-72"	16"-24"
90 SQ. FT.	6" SCH40 (6-5/8" OD)	48"-60"	60"-84"	24"-30"
120 SQ. FT.	6" SCH40 (6-5/8" OD)	48"-72"	72"-84"	24"-30"

* Module Area (SQ. FT) = W (Panel Width in FT) x L (Panel Length in FT)

NOTE: All drawings are only for illustration purposes. It is the installer's responsibility to validate foundation parameters prior to installation, as a local geotechnical report may be required to assess ground conditions. We recommend consulting with a local engineer familiar with local regulations and building site requirements, including soil conditions, terrain and load criteria (wind, snow, seismic). All of these parameters may impact foundation requirements.

Photographs are intended to portray typical module and mount appearance, actual appearance may vary.

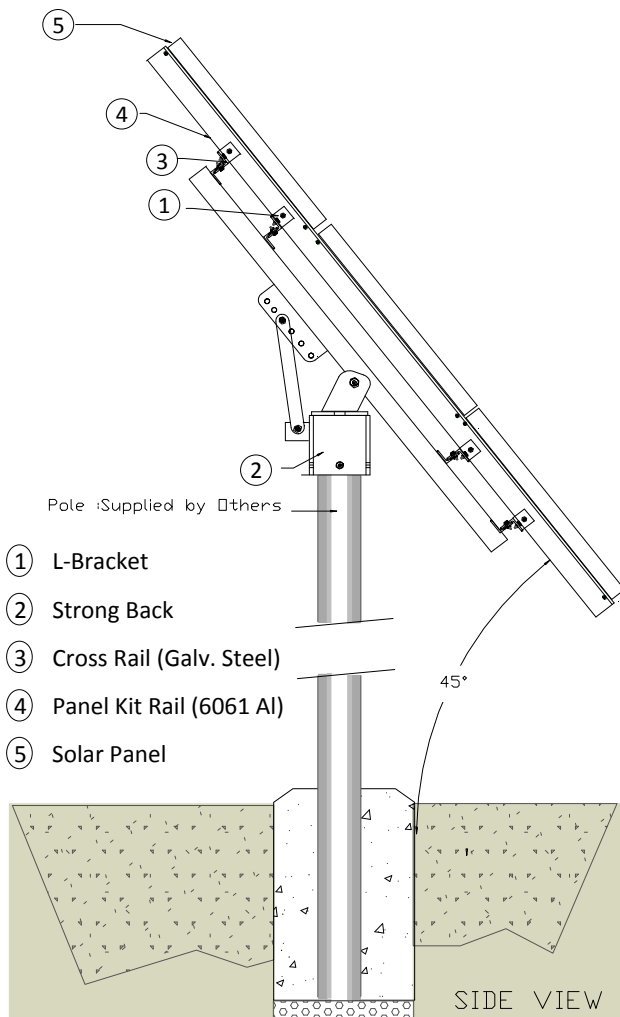

Figure 1. Mounting kit components

Table 2: Mounting Kit Hardware		
Qty.	Item	Description
8	L-Bracket	Aluminum Angle
2 Pair	Panel Kit Rail	Aluminum Angle
1	Strong Back Assembly / Sleeve	Galv. Steel Sleeve to fit pole.
2 Pair	Cross Rail	Galv. Steel Angle
1	316 SS Hardware	Hardware

Figure 2. Attach Panel Kit Rail to Cross Rail using L-Bracket.



When choosing a site, avoid trees, buildings or obstructions which could cast shadows on the solar modules. This is especially true during the winter months when the arc of the sun is lowest to the horizon.

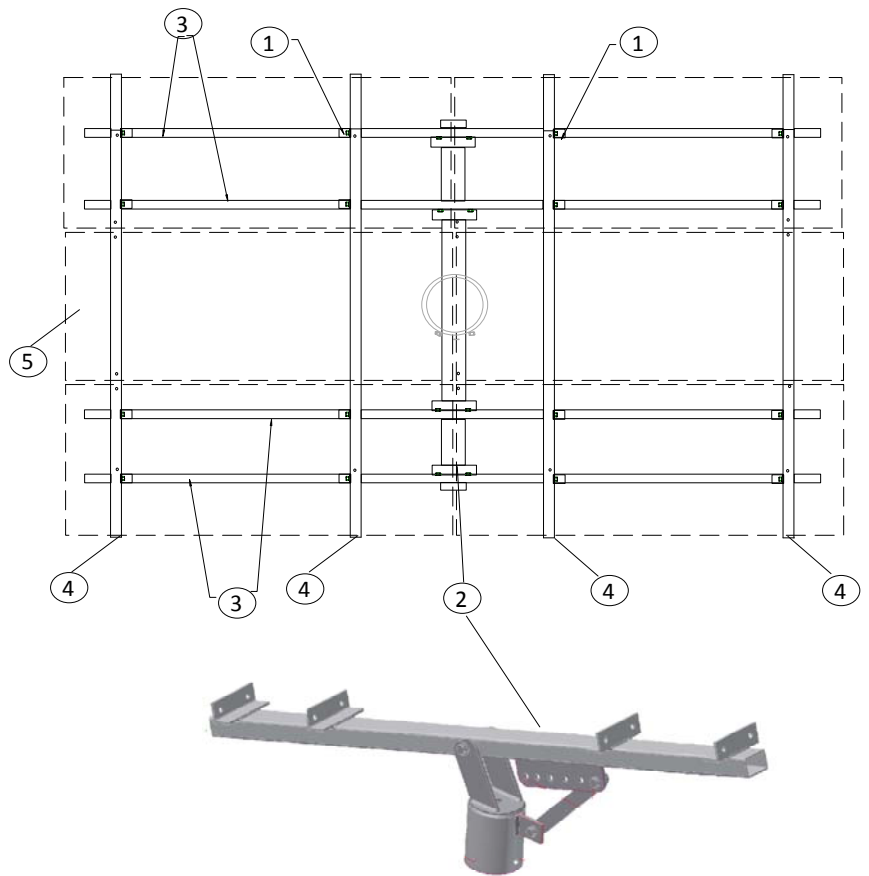

Figure 3. How to Adjust PV Array Tilt Angle.

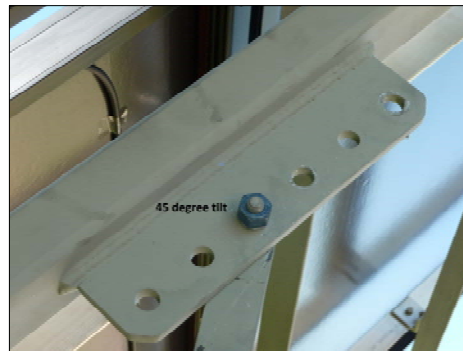

Table3: Select Tilt Angle	
SITE LATITUDE IN DEGREES.	FIXED TILT ANGLE
0° TO 15°	15°
15° TO 25°	SAME AS LATITUDE
25° TO 30°	SAME AS LATITUDE +5°
30° TO 35°	SAME AS LATITUDE +10°
35° TO 40°	SAME AS LATITUDE +15°
40° +	SAME AS LATITUDE +20°

* Note : Recommended Tilt Angles for Fixed Systems Based on Winter Performance.

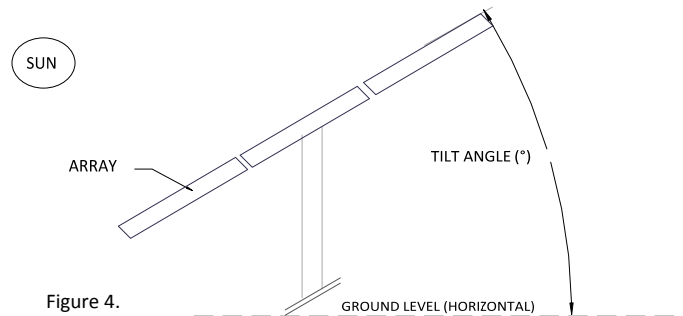

Figure 4.

Locate array in an unshaded area facing equator and tilted from the horizontal as follow: See Figure 4.